

X82FD

2x 8" HIGH PERFORMANCE TWO-WAY
ACTIVE FULL-RANGE SPEAKER SYSTEM

XCELLENCE



Dante™
Act+ve

The X82FD constitutes a significant improvement in high-performance point source design, featuring a lightweight and compact 8" format based on the successful 2x10" concept of the best-selling X102FD. This model is engineered to deliver outstanding acoustic power with exceptional vocal articulation. In its reduced dimensions, the X82FD achieves remarkable maximum SPL levels. The perfect choice for medium-sized applications requiring high sound quality and efficient space utilization, setting new standards in portability and acoustic performance.

KEY FEATURES

TRANSDUCERS TECHNOLOGY

Two-way full range active speaker system composed by two direct radiating 2-inch long excursion dual voice coil, neodymium magnet 8" loudspeakers and one 3-inch voice coil, titanium diaphragm, neodymium magnet compression driver loaded to a 80° x 60° horn.

AMPLIFICATION

3000 W 3rd generation Class D built-in amplifier controlled by a dedicated multichannel DSP.

90% efficiency amplifier SMPS (switching mode power supply), allowing maximum power delivery with minimum consumption in an extremely low-weight and reduced size.

Exclusive and unique Overvoltage Protection which continuously monitors line voltage and instantly disconnects the system if the line voltage exceeds the maximum permissible level.

Automatic low power consumption mode (EcoMode) available, when no signal present at the input.

Double PowerCon® (input & link).

DSP & CONTROL

ACTIVE+ DSP technology with all necessary signal processing (crossovers, EQ's, delay, limiters, gain control, mute) as well as several useful presets to adjust the X82FD to different requirements.

Advanced signal processing using F.I.R. (Finite Impulse Response) filters.

Rear connections and control panel with 3.5" TFT colour touch screen to display the different settings, presets, volume and adjustments done by the user.

Automatic input overload prevention circuit: prevents overloading the A/D converter input.

Double Ethernet connection with integrated Ethernet switch and Dante™ audio networking protocol that uses standard IP networks to receive high-quality, uncompressed audio with near-zero latency.

New DSPStudio® control software capable of adjusting and setting-up even the finest details and monitoring key parameters of the amplifier: input and output levels, limiter engagement, amplifier temperature and status, and network connection status.

DESIGN & ACCESSORIES

M8 rigging points for easy flying.

Ergonomic handle for an easy and comfortable transport.

1.5mm speaker grille with grey micro-foam cloth, exclusively designed with an optimum perforation gradient and attractive appearance.

Multilayer baltic birch plywood cabinet with Polyurea® coating, offering maximum reliability and strength for touring as well as for high demanding applications.

35mm diameter pole mount socket mounted on the bottom side for a standard tripod.

Protective rubber profiles.

X82FD

2x 8" HIGH PERFORMANCE TWO-WAY
ACTIVE FULL-RANGE SPEAKER SYSTEM

XCELLENCE



**DSP STUDIO CONTROL
APP FOR WINDOWS AND
MAC**



**EXCLUSIVE HIGH
PERFORMANCE
HORN**



**LIGHT NEODYMIUM
COMPONENTS**



**> 250 V
OVERVOLTAGE
PROTECTION**



**MULTIPLE PRESETS
AVAILABLE**



**HIGH RESISTANT
POLYUREA® PAINT**



**ACCESSORIES FOR
EASY INSTALLATIONS**

TECHNICAL FEATURES

Amplifier (program power)	2500 W (LF) + 500 W (HF) Class D Bi-amplified
Analog input	Nominal: +8 dBu. Max: +20 dBu. Impedance: 20 kΩ Balanced
Audio networking	Dante™ audio networking input, 1 channel, 48kHz
Mains	Universal Switch Mode Power Supply 85-265 V / 45-65 Hz
Average current draw	2.9 A (Heavy duty musical program)
SPL (1 m)	134 dB continuous musical program, 137 dB peak
Built-in DSP	64-bit processing unit. Includes factory presets
AD/DA converters	24 bit – 48 kHz
Standby mode consumption	< 5 W
Adjustable delay line	294 ms / 100 m
Crossover frequency	800 Hz
Frequency response (-10 dB)	68 Hz – 19 kHz
Components	LF 2x 8" neodymium woofers (2" long excursion dual voice coil) HF 1x 3" titanium diaphragm, neodymium magnet compression driver
Directivity (-6 dB)	80°(H) x 60°(V)
Directivity factor (Q)	12.6
Directivity index (DI)	11 dB
Weight	23 Kg
Dimensions (HxWxD)	624 x 303 x 402 mm
Finish	Multilayer baltic birch plywood with high resistant black Polyurea® coating and protective rubber profiles
Grille	1.5 mm steel with grey micro-foam cloth
Rigging	M8 points
Connectors	1x XLR input / 1x XLR link / 1x AC PowerCon® input / 1x AC PowerCon® link / 1x EtherCon® RJ45 input / 1x EtherCon® RJ45 link



TOP VIEW



BOTTOM VIEW



FRONTAL VIEW
WITHOUT GRILLE



SIDE VIEW



REAR VIEW

X82FD

2x 8" HIGH PERFORMANCE TWO-WAY
ACTIVE FULL-RANGE SPEAKER SYSTEM

XCELLENCE



FREQUENCY RESPONSE 1w/1m (FR FLAT PRESET)

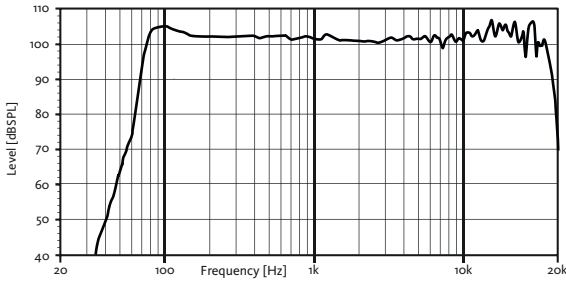

HORIZONTAL COVERAGE

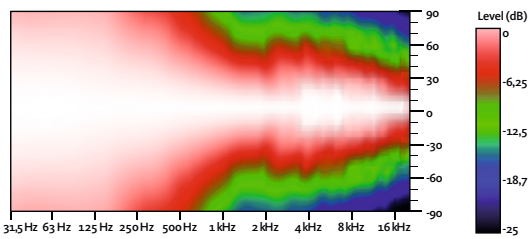

VERTICAL COVERAGE

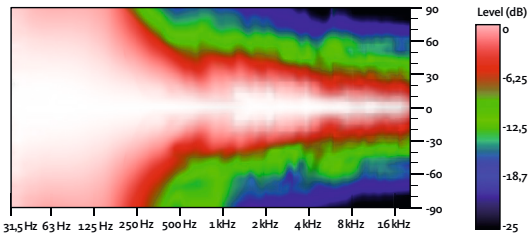

HORIZONTAL & VERTICAL BEAMWIDTH (-6dB point)

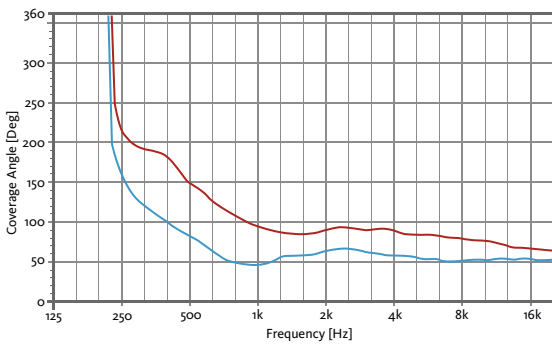

HORIZONTAL VERTICAL

DIRECTIVITY INDEX (Di)

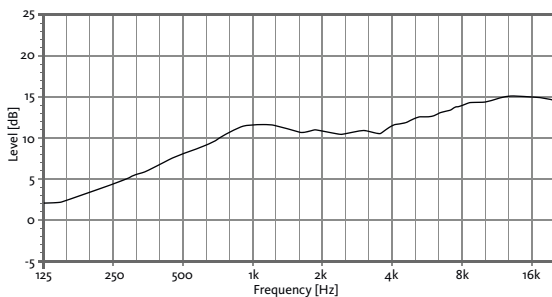

CAD DRAWING SCHEME

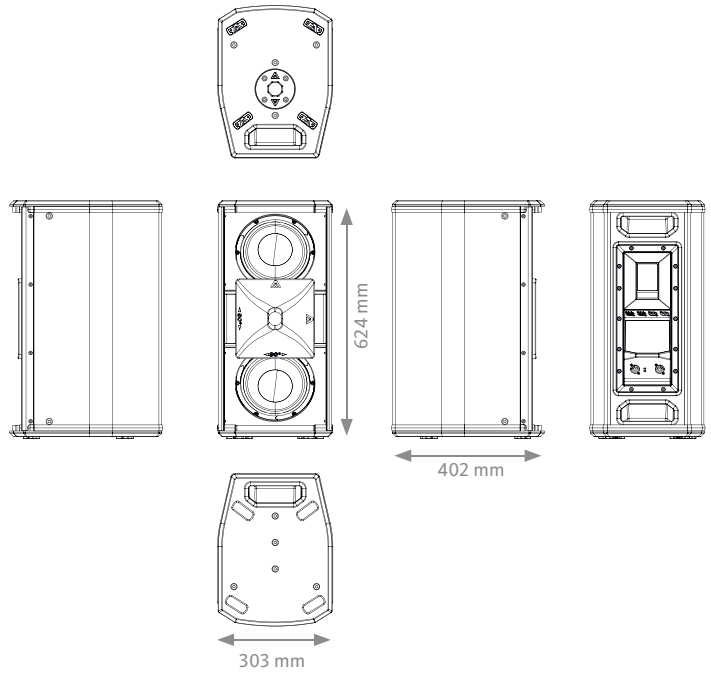

DSP STUDIO 4 CONTROL SOFTWARE

The 4th generation of the DSPStudio software allows the remote control and monitoring of the device via Ethernet. Ready for both Windows and MacOS, and also touchscreen friendly, the software allows the control of several devices associated in arrays and groups. An offline mode is also available, so you can create your project without the need of a live connection with the devices.

Three different views are available:

- **Config Page:** add your devices in the desktop, assign names and organise them in arrays, groups and views.
- **Tuning Page:** ready to use when tuning the system. Assign individual or global gain, PEQ or delays to the devices, groups or arrays
- **Live Page:** Monitor constantly the status of the system. Limiters, temperature and mains voltage



Download it from our website: www.amateaudio.com

X82FD

2x 8" HIGH PERFORMANCE TWO-WAY
ACTIVE FULL-RANGE SPEAKER SYSTEM

XCELLENCE



ACCESSORIES

FLIGHT CASE FC-X82FD
for two units of X82FD



FLYING BAR RB-S
for one cabinet



FLYING BAR WITH HOOK RB-S/GT
for one cabinet



WALL-MOUNT BRACKET SP-WHR



SAFETY SLING SC-15



M8 RIGGING EYEBOLT ACR-M8



TELESCOPIC DISTANCE ROD SP-CRTL

ø: 35 mm
Length: 55 cm ~ 90 cm
Thread: M20



PROTECTIVE COVER NC-X82FD
for one unit of X82FD



REAR CONTROL PANEL TOUCHSCREEN



VERTICAL WALL-MOUNT / SP-WHR + SC-15

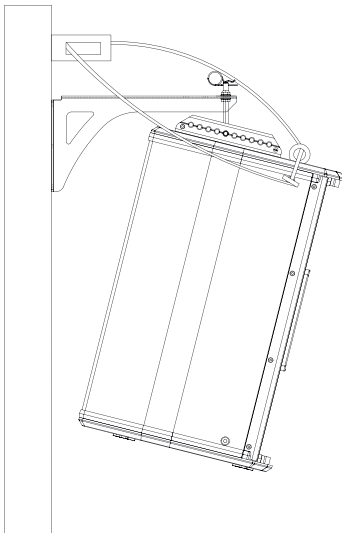

VERTICAL COLUMN-MOUNT / RB-S + SC-15

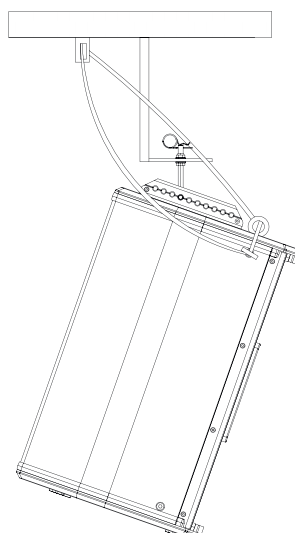

VERTICAL TRUSS-MOUNT / RB-S/GT + SC-15

